



IN VIDEO

Mechanical Presses

from 6 to 80 Tons

Mechanical Presses 6 T - 15 T - 25 T - 45 T - 80 T

The range of EMG mechanical presses consist of 5 models from 6 to 80 T.

Being performance-oriented, these execute the most demanding applications with precision and reliability: watchmaking, jewellery, mechanical optics, electrical and electronic machines, automotive industry, electrical goods, toys, locksmithing...

Being durable, these guarantee you optimum quality and unparalleled productivity for a very long time!

The various operations are executed carefully thanks to the power reserve of each model and a very rigorous precision.



TECHNICAL CHARACTERISTICS:

	6 T	15 T	25 T	45 T	80 T
Variable stroke (mm)	4 ▶ 40	5 ▶ 75	5 ▶ 75	6 ▶ 100	8 ▶ 120
Clear height (mm)	200	300	300	350	400
Swan- neck depth (mm)	120	180	210	220	300
Number of cycle / mn	240	140	140	130	100
Adjustment of the swivel screw	0 ▶ 30	0 ▶ 50	0 ▶ 60	0 ▶ 70	0 ▶ 90
Slider bore (mm)	Ø26H7x40	Ø38H7x55	Ø38H7x55	Ø50H7x65	Ø50H7x100
Motor power (kw)	0,5	1,1	2,2	5,5	7,5
Air consumption per cycle (l.)	0,2	0,6	0,7	0,9	0,7
Table dimension (mm)	450x220x30	450x320x40	550x400x48	650x430x57	850x600x67
Weight (kg)	450	900	1 400	3 100	6 300

Mechanical Presses

Characteristics of the Range

• Frame

The frame is made of high quality mechanized welded steel with swan-neck structure. Regular weld seams and proper welding supports ensure an exceptional rigidity and a resistance against cutting impacts even during an intensive use.

The very thick sides of the frame reduce the swan-neck opening.

• Slider

The slider is made of cast iron FGS 300 mounted on steel or bronze sliding rails, adjustable by screws. The assembly is completely adjusted and scraped manually. The adjustment is carried out by stops mounted on the press frame.

The bedplate of the slider has holes and a central bore for fixing tools.

The sliding rails have machining in the form of "oil grooves" allowing an efficient lubrication.

A knock-out bar goes through the slider. The adjustment is carried out by a stop mounted on the frame.

• Connecting rod/Swivel screw

The connecting rod is made of FGS 300 cast iron (steel on 80T) with bronze line completely scraped ensuring a perfect lubrication. It is lubricated by oil.

The swivel screw is made of pre-treated steel, completed by a surface treatment.

• Shaft

The shaft is made of hardened forged steel. An over-sulfurization after machining reduces the wear and tear due to friction. It runs on lubricated rings.

• Stroke change

The stroke change is achieved very quickly by turning the disconnecting device of a turn and then selecting the desired stroke length.

• Lubrification

The lubrication is centralized and ensured by a manual pump. The frequencies are to be adapted as per the cycles used (single or continuous stroke working).

Automatic pump (optional).

• Twin-body solenoid valve

It is self-controlled and assembled with heavy duty silencers.

• Clutch/Brake

The movements of the press are obtained by a monodisc air clutch and managed by a brake. An air reservoir compensates for the possible failures of the network starting from the 25t model.



Standard control panel for mechanical presses

Mechanical Presses

Standard Equipment

- Two hand controls with push buttons.
- Central greasing by manual pump
- 6 digit counter with reset function, 8 digit counter without reset function
- Single or continuous stroke
- 20° inclinable frame (option 45t and 80t)
- Regulation with or without motor
- Positive ejector in the slider
- Balancing cylinders (45t and 80t)
- Slider hydraulic unblocking (45t and 80t)

- Automatic unblocking for the stroke adjustment (80t)
- EC compliance certificate
- User manual and electrical, pneumatic and hydraulic diagrams
- Periodical verification guide (regulatory follow-up, verification procedures, preventive maintenance, faults and remedies)

Mechanical Presses

6, 15 and 25 Tons



6 T

Stroke	Height at bottom dead center	Height at top dead center
4	178	182
10	175	185
18	171	189
25	167	192
32	164	196
36	162	198
39	160	199
40	160	200

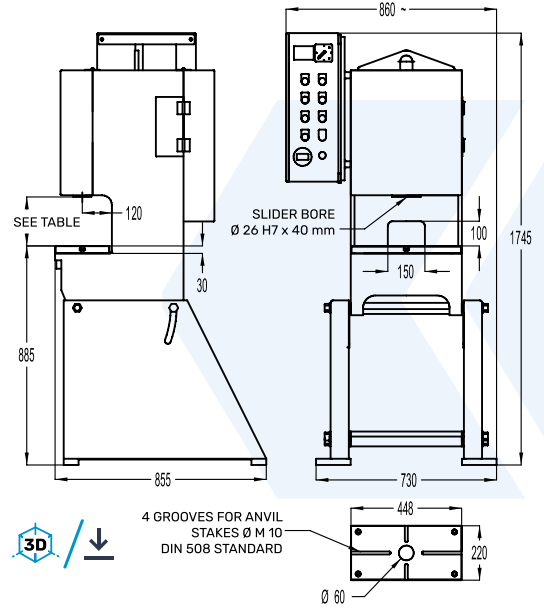

15 T

Stroke	Height at bottom dead center	Height at top dead center
5	261	266
20	253	273
38	245	283
53	237	290
65	231	296
72	227	299
75	226	301

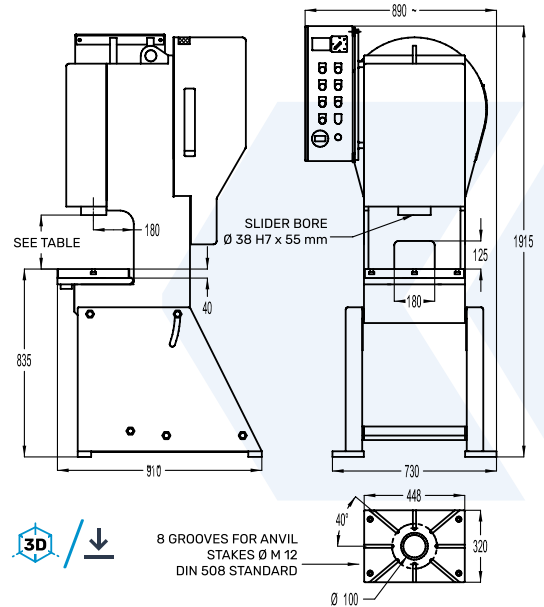

25 T

Stroke	Height at bottom dead center	Height at top dead center
5	262	267
13	258	271
24	252	276
34	248	282
44	242	286
53	238	291
61	234	295
67	231	298
71	229	300
74	227,5	301,5
75	227	302

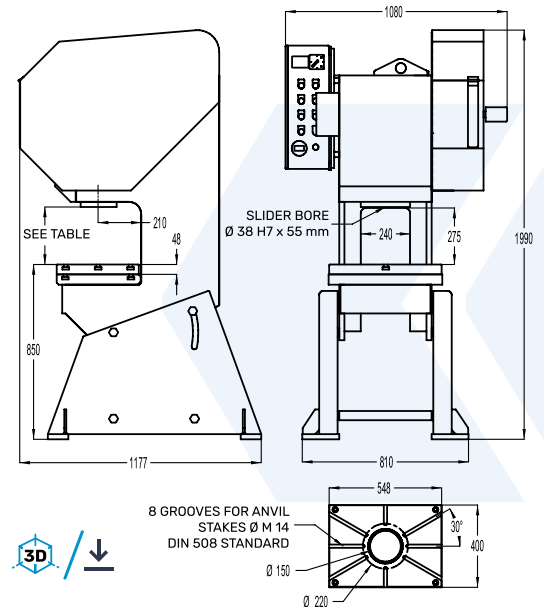

Mechanical Presses

45 and 80 Tons



Stroke	Height at bottom dead center	Height at top dead center
6	299	305
14	295	309
26	289	315
39	282	321
50	277	327
61	271	332
71	266	337
79	262	341
86	259	345
92	256	348
97	253,5	350,5
99	251,5	351,5
100	252	352

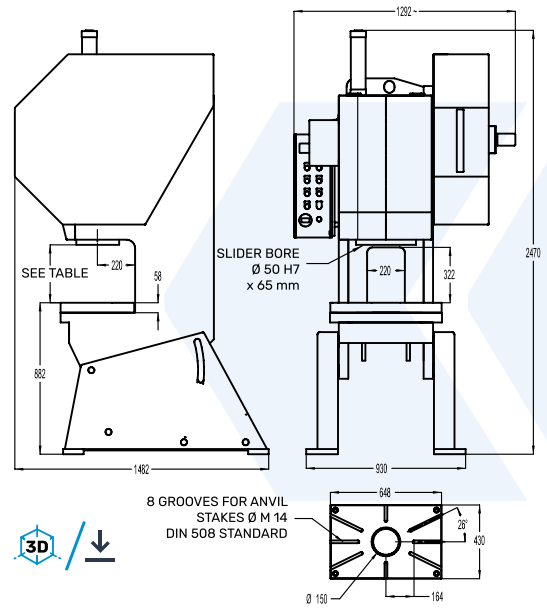

Stroke	Height at bottom dead center	Height at top dead center
8	332	340
18	328	346
32	321	353
46	314	360
60	306	366
73	300	373
85	295	380
95	290	385
104	285	389
111	282	393
116	279	395
119	278	397
120	278	398

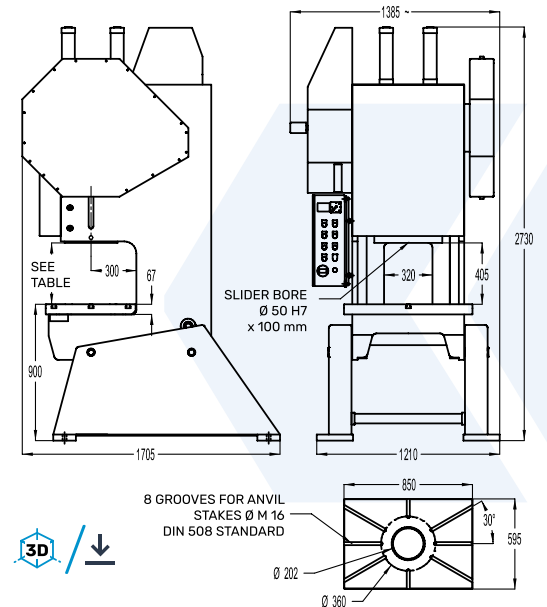

Standard control panel



A 5" touch screen, easily accessible for the operator, allows the operation of the press and the access to the various menus (work cycles, information, statistics, faults, etc).



Mechanical Presses

Complete Lines with Unwinder, Straightener, Feeder

EMG PRESSE creates full and customized manufacturing lines bands or for threads

Production equipment components are selected from our partners by our design department to ensure that your specifications and your requirements regarding profitability and quality are respected. They are compliant with all the strictest regulations.

A full production line generally includes:

- A standard or modified eccentric mechanical press from the EMG product line,
- A single or double decoiler for strips or wires,
- A roller straightener for strips or wires,
- A pneumatic or electronic feeder for strips or for wires,
- A pair of trimming shears or a uncoiler for strips or for wires.

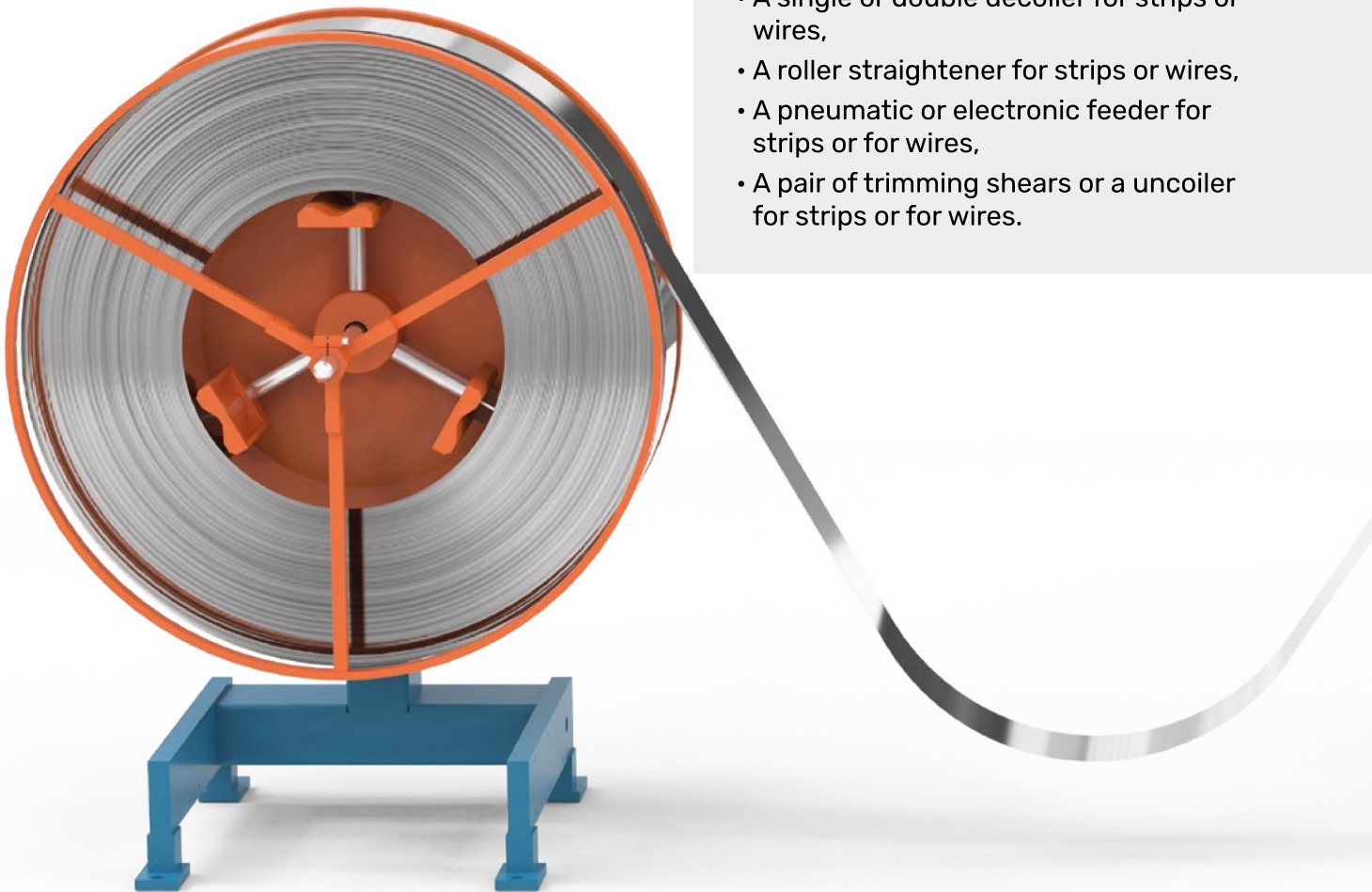

Each production line is designed using the most stringent ergonomic principles and uses all protective equipment and barriers required for maximum operator safety.

They make it possible to manage a wide range of dimensions both in the length and thickness of the strips and various profiles, in a variety of materials to be straightened and cut, taking into account the most complex parameters of materials with high or low elastic limits.

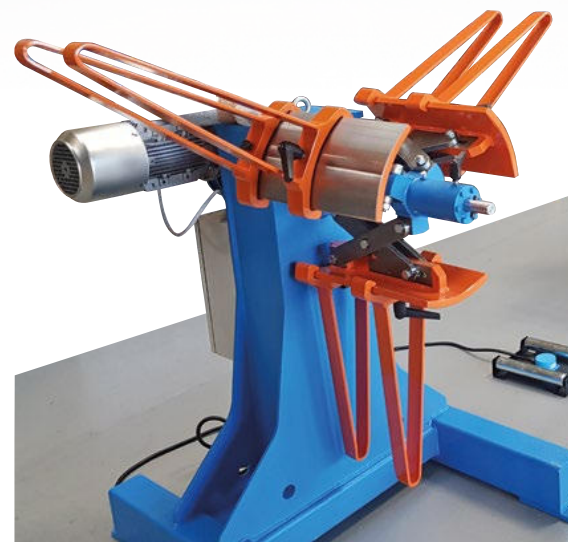

Mechanical presses

Complete Lines with Unwinder, Straightener, Feeder

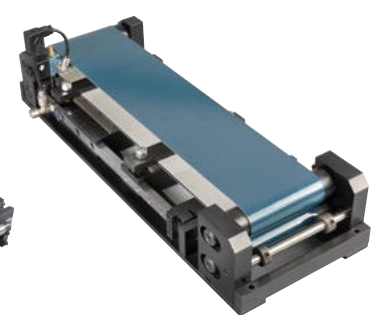
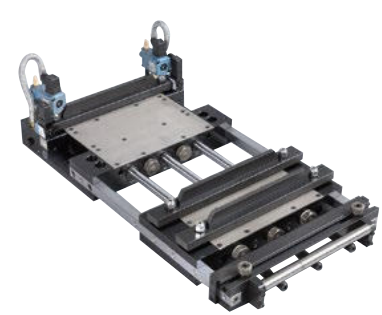
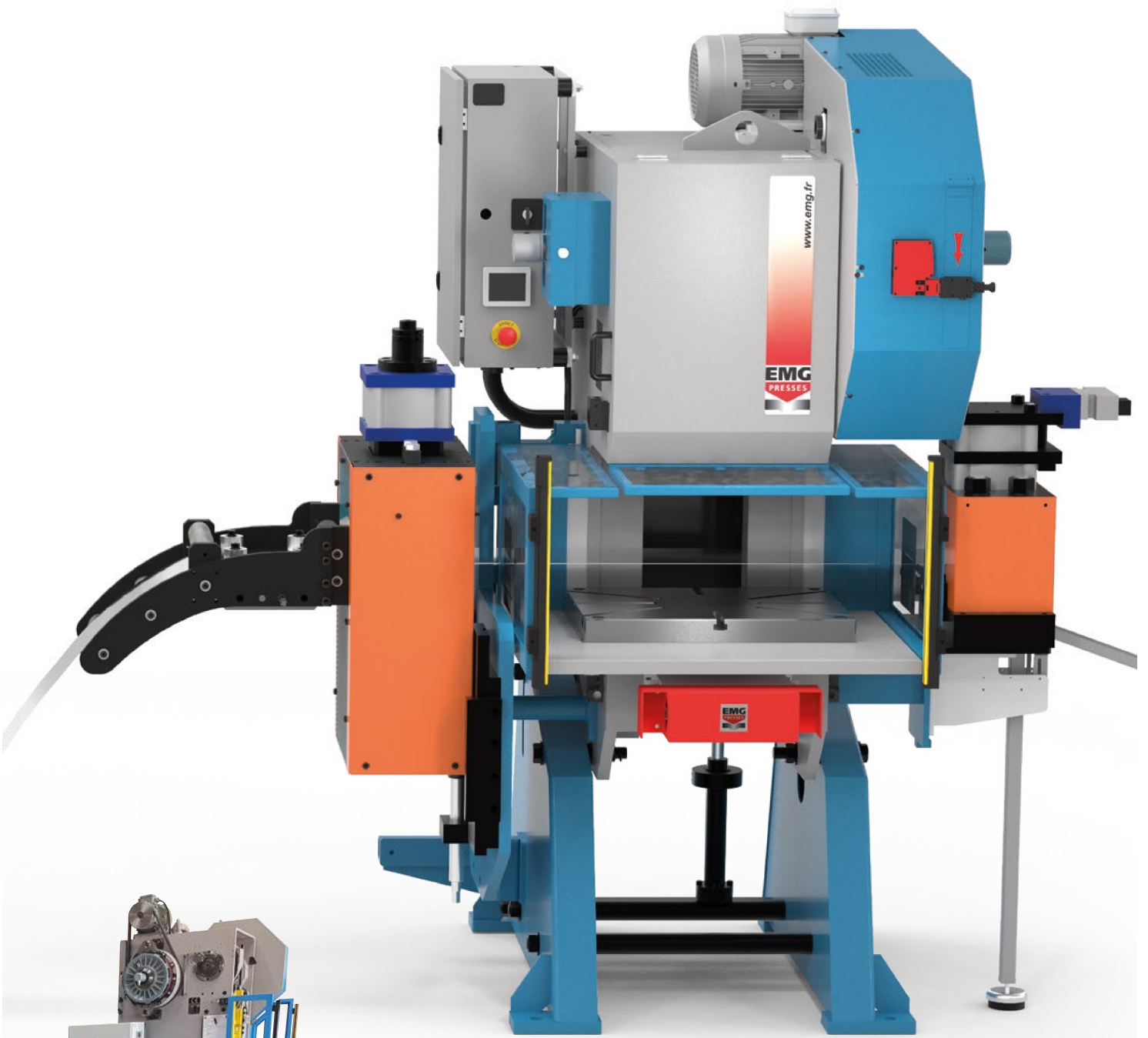

Options

VERTICAL SCREEN



The automatic vertical screen ensures front and side protection of the operator and third party. A support on the pedal ensures the descent of the screen to its bottom dead center, the start of the cycle authorized only if the proximity edge does not encounter any obstacle.

The operator can work with both hands free for loading or unloading parts even if the tool is not secured.

This machine gives you about 20% increased productivity with less fatigue and muscle strain.

Doors are mounted on hinges providing full access for quick and easy tool changing.

ELECTRONIC GUARDS



Electronic guards allow front protection of the dangerous zone and control the start of the cycle after one or two passes in the beam. Not requiring any use of two hand controls, this equipment ensures maximum safety while improving press productivity.

It is also possible to work with simple protection by using the pedal for starting the cycle.

Doors are mounted on hinges providing full access for quick and easy tool changing.

MECHANICAL UNLOCKING WEDGE (hydraulic and standard on 45T and 80T)

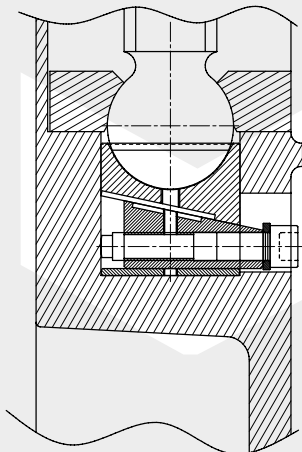

The bottom dead center slider unlocking wedge allows unlocking your press in a few minutes, without any change of parts.

ELECTRONIC CAM



The electronic cam programmer from OMRON, associated with its encoder, allows managing 8 outputs in order to manage a feeding device, blower, pilot release, cutting unit or any other machine periphery.

AUTOMATIC GREASING WITH LEVEL MONITORING (standard on 45T and 80T)



Automatic lubrication is done in place of manual centralized greasing.

It ensures better lubrication of the machine without any risk of omission by the operator.

This option is strongly recommended in case of automatic working.

RUBBER STRIPPER (6T, 15T and 25T)

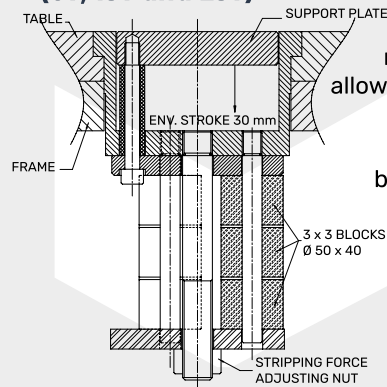

Rubber stripper, mounted on table bore, allows ensuring the ejection of tooling parts.

Its power is adjustable by adjusting the tension of the rubber contacts.

PNEUMATIC STRIPPER (25T, 45T, 80T)



Ensuring the same function as the rubber stripper, the pneumatic stripper delivers more significant power, from 3t on 25T and 45T presses, to 7t on 80T presses.

Its air tank ensures constant pressure.

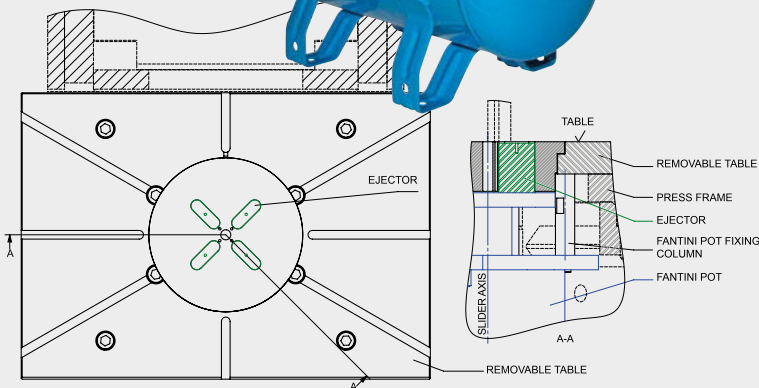
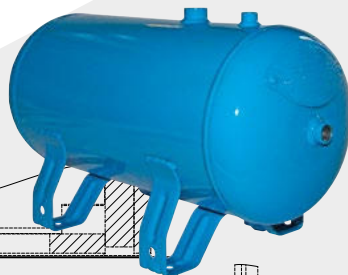

SPEED VARIATOR WITH SELECTION BY POTENTIOMETER



In order to adjust the stroke rate of the press in the automatic work cycles, or for a slow descent in regulation with motor phase, all the mechanical presses can be delivered with a speed variator, adjustable by potentiometer.



Additional options ///

- Pedal control for working with embedded tools or stroke < 6 mm.
- Supply cam with 3/2 valve and closing valve.
- 6 digit preselection counter in order to stop the press as soon as the quantity is reached.
- Halogen or neon or LED lamp lighting on 500 flexible lines.

- Expansion chamber on exhaust for reducing the sound levels (-2dB).
- Set of anvil stakes.
- Anti-vibration supports.
- Special RAL paint.

*Definition: The embedded tools must be intrinsically safe. Their corresponding openings and safety distances must be in compliance with the standards in force or must not exceed 6 mm. Any risk of additional deformation outside the embedded tools must be avoided.